

Databits: 8 Parity: none Stop bits: 1 or 2 Protocol: Modbus RTU	Supported Modbus functions: 03 - read multiple registers 06 - write single register
--	---

Modbus registers (0-based, decimal format)

Reg	Description	Supported values
1	Hardware version	read only
2	Software version	read only
3	Product serial number	read only
4	Slave ID (network address)*	1...247, default 1
5	Baudrate*	1200...57600 baud, default 9600
6	Response delay, ms	10...255 ms, default 10
7	Stop bits*	1 / 2, default 1
17	Restart	write '42330' for soft restart
162	Temperature shift adjustment	-32000...+32000 T units (0,01 °C)
165	Gas channel shift adjustment	-32000...+32000 gas units, default 0
166	Gas channel slope adjustment	1...65535, default 512
167	Output change rate limit	1...32000 gas units/s, 0=no limit
168	Integrating filter time constant	1...32000 s, 0=no integrating filter
201	Parameter assigned to OUT1	0=none, 1=T, 2=gas, 9=forced by 203
202	Parameter assigned to OUT2	0=none, 1=T, 2=gas, 9=forced by 204
203	Forced value for OUT1	0...1000 (0.0...100.0% of full scale)
204	Forced value for OUT2	0...1000 (0.0...100.0% of full scale)
211	Parameter assigned to RE1	0=none, 1=T, 2=gas, 9=forced by 213
212	Parameter assigned to RE2	0=none, 1=T, 2=gas, 9=forced by 214
213	Forced state for RE1	0=off, 1=on (relay control by Modbus)
214	Forced state for RE2	0=off, 1=on (relay control by Modbus)
215	Switch delay for RE1	0...1000 s, default 0
216	Switch delay for RE2	0...1000 s, default 0
217	Min on/off time for RE1	0...1000 s, default 0
218	Min on/off time for RE2	0...1000 s, default 0
219	Control logic for relay RE1	0:_, 1:↓↑, 2:↑↓, 3:↑↓, 4:↓↑
220	Control logic for relay RE2	0:_, 1:↓↑, 2:↑↓, 3:↑↓, 4:↓↑
221	LOW setpoint for relay RE1	-32000...+32000, gas or T units
222	HIGH setpoint for relay RE1	-32000...+32000, gas or T units
223	LOW setpoint for relay RE2	-32000...+32000, gas or T units
224	HIGH setpoint for relay RE2	-32000...+32000, gas or T units
258	Measured temperature	-4000...+12500 T units (0,01 °C)
259	Gas concentration	0...65535 gas units
261	0% value of OUT1	-32000...+32000 gas units / integer °C
262	100% value of OUT1	-32000...+32000 gas units / integer °C
263	0% value of OUT2	-32000...+32000 gas units / integer °C
264	100% value of OUT2	-32000...+32000 gas units / integer °C

* - the new value is applied after restart

Broadcast ID=0 may be used to assign a new ID to device with unknown ID

Specifications

Detection ranges	400...5 000 ppm CO ₂ 400...10 000 ppm CO ₂ 400...50 000 ppm CO ₂
Resolution	1 ppm CO ₂
Accuracy	± (50 ppm + 2% of value) CO ₂
Response time	~60 seconds
Signal update	every 15 seconds
Warm-up time	≤ 1 min
Sensor type	long-life optical NDIR sensor
Sensor lifetime	> 15 years
Sampling method	diffusion
Analog outputs	2 × 4-20 mA or 0-10 V, user settable
Load resistance	R _L < (U _s - 3 V) / 22 mA for 4-20 mA R _L > 100 kOhm for 0-10 V mode:
Operating conditions	-40...+60 °C, 0...95 %RH, 85...110 kPa
Power supply	11...30 VDC
-with integrated mains supply module	90...265 VAC
Power consumption	< 2 VA
Electromagnetic compatibility	according to 2014/30/EU, 2014/35/EU and EN61326-1 requirements
Enclosure	light-grey ABS 82×85×55 mm, IP65
Relays	2 × SPST, max 5 A, 30 VDC / 250 VAC

Delivery set

-Carbon dioxide detector-transmitter E2608-CO2 or E2608-CO2-DM

- Mounting accessories:

-4 cross-shaped mounting lug with screws and 4 screws with plastic dowels for wall mount version

-rubber flange with 3 self-tapping screws for duct mount version

-fixing clamp for remote probe versions

Warranty

This product is warranted to be free from defects in material and workmanship for a period of one year from the date of original sale. During this warranty period Manufacturer will, at its option, either repair or replace product that proves to be defective. This warranty is void if the product has been operated in conditions outside ranges specified by Manufacturer or damaged by customer error or negligence or if there has been an unauthorised modification.

Factory settings

Target gas	Carbon dioxide CO ₂
Gas units	ppm
OUT1 assignment and scale	2: gas, 400 - 5 000 / 10 00 / 50000 ppm
OUT2 assignment and scale	2: gas, 400 - 5 000 / 10 00 / 50000 ppm
RE1 assignment and logic	2: gas, 1: on at high values
RE1 HIGH setpoint (set)	according to user's preferences
RE1 LOW setpoint (release)	according to user's preferences
RE2 assignment and logic	2: gas, 1: on at high values
RE2 HIGH setpoint (set)	according to user's preferences
RE2 LOW setpoint (release)	according to user's preferences

Carbon Dioxide Detector-Transmitter
E2608-CO2

User Manual

Carbon dioxide detector-transmitter E2608-CO2 is a member of new PluraSens® family of multifunctional measurement instruments. Applications include HVAC and air quality control in public, office and industrial buildings, greenhouses, underground parkings, boiler houses, and other confined spaces, where potentially toxic concentration of carbon dioxide can accumulate. The instrument utilises optical NDIR gas sensor with excellent repeatability, stability and long lifetime

The detector is supplied either in duct-mount or wall-mount version. The wall mount version of the device is available with remote probe. The remote probe is connected to the main unit with shielded cable. The connection cable length options are 2.5 m or 5 m. E2608 provides two independent analog outputs OUT1 and OUT2, user-selectable to 4-20 mA or 0-10 V, proportional either to gas concentration or temperature. RS485 Modbus RTU digital communication interface allows easy instrument configuration and integration into various automation systems. Two relays RE1 and RE2 with closing contacts can be used to switch 24 V or 230 V powered alarm sirens, ventilation fans, shut-off valves or other actuators.

Safety requirements

Always adhere to the safety provisions applicable in the country of use.

Do not perform any maintenance operation with the power on. Do not let water or foreign objects inside the device.

Operating conditions

The device should be used in explosion-safe (non ATEX -rated) indoor areas, without aggressive gases in the atmosphere. See Specifications table for more details.

Installation and connections

1. **Duct mount version:** Connect the sensor probe to the device main unit. Make sure that the connections are tightened properly.

Cut a 30 mm diameter hole in the air duct at the chosen mounting place. Place the rubber flange in the hole and fix it with three self-tapping screws. Pass the sensor probe through the flange and adjust it to the appropriate depth. Unscrew four lid screws and detach the lid from the instrument.

Wall mount version: Unscrew four lid screws and detach the lid from the detector. The gas detector should be mounted on a wall at a place located not more than 5 m from possible gas source and not very close to ventilation openings. It is advisable to place acetylene detector at 1,4-2 m from the floor, with the sensor pointing downwards.

Fix the detector on a wall by screws, using cross-shaped mounting lugs supplied with the instrument (see dimensional drawing below).

The device should be mounted in proximity to potential acetylene sources and away

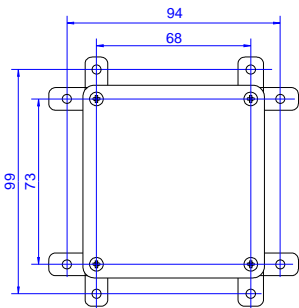

from the ventilation holes or dead-air spaces such as corners. Acetylene is slightly lighter than air (0,9 of air density) and tends to spread evenly in the room. The sensor should be placed at 1,4..2 m from the floor, pointing downwards. Recommended coverage area for each detector-transmitter is 500...1000 m² (12...18 m radius).

2. To power the instrument from an external 24 VDC source, connect terminals 0V and +U to the source. If the integrated mains power supply module is used, connect terminals L and N to the mains.

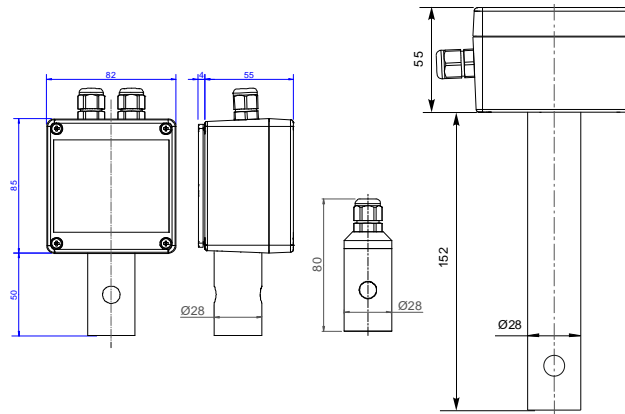

NB! If the instrument is powered from mains, connect to 0V and +U terminals only light external loads, which consume less than 30 mA in total, as the integrated mains supply module capacity is limited.

3. To use analog outputs, connect the terminals OUT1 and/or OUT2 and 0V to the input of the secondary instrument (indicator or controller). **NB!** The outputs are not galvanically isolated from 24 V power supply and share common 0V. Allowed load resistance limits are stated in Specifications table.

The type of each analog output can be independently selected with the appropriate jumper (J1 for OUT1 and J2 for OUT2). With jumper open, the output type is 4-20 mA. With jumper closed, the output type is 0-10 V.

4. To use relay outputs, connect the chosen actuators to the relay terminals RE1 and/or RE2. **NB!** Actuator short-circuits shall be avoided, to protect the instrument relays use external fuses or safety switches.

5. When the detector is fixed and the external devices connected, replace the lid and fix it with the screws.

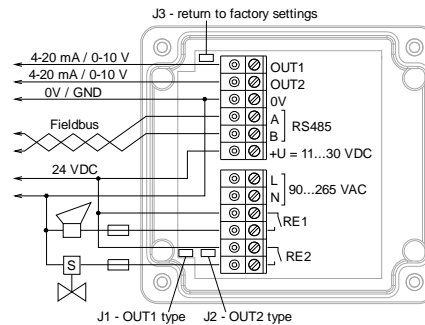

Sensor probe handling

The wall mount version of the transmitter is available with remote probe. The remote probe is connected to the main unit with shielded cable. The connection cable length options are 2,5 m or 25 m.

NB! Never stab or press the ventilation hole in the sensor probe since this may damage the sensor.

The recommended orientation of sensor probe is vertical with the sensor tip pointing downwards. This prevents possible accumulation of condensed water on the sensor protection.

Configuring

Gas detector E2608 shares all functionalities of the PluraSens® multifunctional transmitter platform. The features and options include:

- digital output change rate limiting filter
- digital integrating (averaging) filter
- temperature measurement channel with internal sensor
- free assignment of each analog output to chosen parameter
- flexible setting of analog output scales for each output
- output shift and slope adjustment for calibration
- free assignment of each of two relays to chosen parameter
- several relay control logic modes (HI or LO with hysteresis, U or Π)
- switch delays and minimum on/off state durations for each relay
- Modbus controlled forced state option for analog outputs and relays.

E2608 can be configured through its RS485 interface by Modbus RTU commands. A standard configuration kit includes Model E1087 USB-EIA485 converter and E26XX Configurator software.

Calibration

Two optical sensor options are available.

Type A double-beam sensor has a built-in reference sample for autocalibration. Manual calibration by fresh air should be performed once in 5 years.

Type B sensor performs autocalibration by settling the minimal CO2 concentration to 400 ppm. The manual calibration by fresh air should be performed once a year.

To use this type it is required that CO2 level decreases to fresh air level at least once a week. Transmitters with B-type sensors should not be used in areas with constantly high CO2 level (greenhouses, hospitals etc).

Emergency mode

The current outputs of the detector may be programmed via Modbus commands to signal if the connection with the sensor is lost. The signal may be set to 3,8 mA or 21,5 mA. See the table of Modbus registers for more information. Return to default settings

To reset the device's Slave ID, baudrate and sbit number to factory settings, proceed as follows:

1. De-energize the device
2. Connect the J3 jumper
3. Turn on the device
4. De-energize the device
5. Disconnect the J3 jumper
6. Turn on the device

E2608 series Modbus RTU Communication Reference

Modbus holding registers

Register addresses are shown 0-based, Addr in hexadecimal, Reg in decimal format.

Modbus holding register numbers MHR are shown in decimal 1-based format, and may be addressed either from 00001 or 40001 base.

Addr	Reg / MHR	RW	Description	Supported values (dec)	Default
0x0001	1	R	Hardware version		-
0x0002	2	R	Software version		-
0x0003	3	R	Product serial number	1...65535	-
0x0004	4	RW	Slave ID (net address) *	1...247 **	1
0x0005	5	RW	Baudrate *	1200, 2400, 4800, 9600, 19200, 38400, 57600	9600
0x0006	6	RW	Response delay, ms	10...255	10
0x0007	7	RW	Stop bits *	1, 2	1
0x0008	8	R	Last error code	1...255	-
Restart counter					
0x0011	17	RW	Restarts counter	write '42330' to restart device (no response will follow)	-
Sensor and output parameters					
0x0091	145	RW	Heater voltage pulse duration, ms	0...1000 ms	0
0x0092	146	RW	Sensor voltage pulse delay, ms	0...995 ms (values 0...4 reserved to set sensor type)	0
0x0093	147	RW	Sensor type specific parameter	0...65535	100
0x0094	148	RW	Sensor type specific parameter	0...65535	100
0x0095	149	RW	Sensor type specific parameter	-32767...+32767	32000
0x0096	150	RW	Sensor type specific parameter	-32767...+32767	100
0x0097	151	R	Sensor type code	0...65535	0
0x0098	152	R	Output units code	0 - ppm, 1 - ‰, 2 - ‰	0

* - The new value is applied after restart.

** - Broadcast slave ID 0 can be used to assign a new ID to device with unknown ID. When addressing by ID 0 the device shall be the only Modbus instrument in the network. The device will not respond to Master command when addressed by ID 0.

*** - This value is dynamic and not kept in EEPROM after restart

RS485 communication interface

Databits: 8 Parity: none Stop bits: 1 or 2 Protocol: Modbus RTU	Supported Modbus functions: 03 - read multiple registers 06 - write single register
--	---

Communication parameters

Parameter	Permitted values	Default
Supported baudrates	1200, 2400, 4800, 9600, 19200, 38400, 57600	9600
Data bits	8	8
Parity	none	none
Stop bits	1, 2	1
Protocol	Modbus RTU	
Modbus functions	03 - read multiple registers 06 - write single register	
Error codes	01 - illegal function 02 - illegal data address 03 - illegal data value 04 - slave device failure (details of last error 04 can be read from register 0x0008)	

E2608 series Modbus holding registers (part 2)

Register addresses are shown 0-based, Addr in hexadecimal, Reg in decimal format.

Modbus holding register numbers MHR are shown in decimal 1-based format, and may be addressed either from 00001 or 40001 base.

Addr	Reg / MHR	RW	Description	Supported values (dec)	Default
0x00A2	162 / 40163	RW	Zero adjustment for temperature data, °C × 100	-32000...+32000 (-320,00...+320,00 °C)	0
0x00A5	165 / 40166	RW	Zero adjustment for gas data, ADC	-32000...+32000 ADC units	0
0x00A6	166 / 40167	RW	Slope adjustment for gas data	1...65535	512
0x00A7	167 / 40168	RW	Change rate limit for gas data, ppm (% _o for O ₂) / s	1...32000, 0 - no limit	0
0x00A8	168 / 40169	RW	Integrating filter time constant, s	1...32000 (seconds), 0 - no filter	0
0x00C9	201 / 40202	RW	Parameter tied to analog output 1	0-none 1- temperature 2- gas concentration 9- forced Modbus control, value set in MHR / 40204	2
0x00CA	202 / 40203	RW	Parameter tied to analog output 2	0-none 1- temperature 2- gas concentration 9- forced Modbus control, value set in MHR / 40205	2
0x00CB	203 / 40204	RW	Forced value for analog output 1***	0...1000 (0,0%...100,0% of output scale)	0
0x00CC	204 / 40205	RW	Forced value for analog output 2***	0...1000 (0,0%...100,0% of output scale)	0
0x00D3	211 / 40212	RW	Parameter tied to relay RE1	0-none 1- temperature 2- gas concentration 9- control by Modbus control, state set in MHR / 40214	2
0x00D4	212 / 40213	RW	Parameter tied to relay RE2	0-none 1- temperature 2- gas concentration 9- control by Modbus control, state set in MHR / 40215	2
0x00D5	213 / 40214	RW	Forced state for relay RE1***	0- off, 1 - on	0
0x00D6	214 / 40215	RW	Forced state for relay RE2***	0- off, 1 - on	0
0x00D7	215 / 40216	RW	Switching delay for relay RE1	0...1000 (s)	0
0x00D8	216 / 40217	RW	Switching delay for relay RE2	0...1000 (s)	0
0x00D9	217 / 40218	RW	Minimal on/off time for relay RE1	0...1000 (s)	0
0x00DA	218 / 40219	RW	Minimal on/off time for relay RE2	0...1000 (s)	0

* - The new value is applied after restart.

** - Broadcast slave ID 0 can be used to assign a new ID to device with unknown ID. When addressing by ID 0 the device shall be the only Modbus instrument in the network. The device will not respond to Master command when addressed by ID 0.

*** - This value is dynamic and not kept in EEPROM after restart

E2608 series Modbus holding registers (part 3)

Register addresses are shown 0-based, Addr in hexadecimal, Reg in decimal format.

Modbus holding register numbers MHR are shown in decimal 1-based format, and may be addressed either from 00001 or 40001 base.

Addr	Reg / MHR	RW	Description	Supported values (dec)	Default	
0x00DB	219 / 40220	RW	Control logic for relay RE1	0- none 1- relay on at high values 2- relay on at low values 3- relay on at values within the range 4- relay on for the values outside rthe range		0
0x00DC	220 / 40221	RW	Control logic for relay RE2	0- none 1- relay on at high values 2- relay on at low values 3- relay on at values within the range 4- relay on for the values outside rthe range		0
0x00DD	221 / 40222	RW	LOW setpoint for relay RE1	0...65535 (ppm / ‰)	0	
0x00DE	222 / 40223	RW	HIGH setpoint for relay RE1	0...65535 (ppm / ‰)	0	
0x00DF	223 / 40224	RW	LOW setpoint for relay RE2	0...65535 (ppm / ‰)	0	
0x00E0	224 / 40225	RW	HIGH setpoint for relay RE2	0...65535 (ppm / ‰)	0	
0x00FF	255 / 40256	RW	Sensor, analog outputs, LED and buzzer status	bit[0]=0/1 - sensor present/absent, read-only! bit[1]=0/1 - analog outputs deactivated/activated, bit[2]= 0/1 - in case of sensor absent, turn signaling off/on analog output1, bit[3]=0/1 - in case of sensor absent, turn on signaling with low current/high current on analog output1; if bit[2]=0 this bit will be ignored, bit[4]=0/1 - in case of sensor absent, turn signaling off/on analog output2 bit[5]=0/1 - in case of sensor absent, turn on signaling with low current/high current on analog output2; if bit[4]=0 this bit will be ignored, bit[6]=0/1 - current/voltage output detected on output1, read-only! bit[7]=0/1 - current/voltage output detected on output2, read-only! bit[8]=0/1 - LED deactivated/activated, bit[9]=0/1 - buzzer deactivated/activated,	62d	
0x0100	256 / 40257	R	Raw temperature data, °C×100	signed integer, -4000...+8500 (-40,00...+85,00 °C)		
0x0101	257 / 40258	R	Raw gas sensor data	ADC data 0...4095		
0x0102	258 / 40259	R	Measured temperature, °C×100	signed integer, -4000...+12500 (-40,00...+125,00 °C)		
0x0103	259 / 40260	R	Gas concentration, ppm / ‰	signed integer, -32000...+32000 (ppm / ‰)		
0x0105	261 / 40262	RW	0% value for analog output 1	signed integer, -32000...+32000 (ppm / ‰)	0	
0x0106	262 / 40263	RW	100% value for analog output 1	signed integer, -32000...+32000 (ppm / ‰)	1000	
0x0107	263 / 40264	RW	0% value for analog output 2	signed integer, -32000...+32000 (ppm / ‰)	0	
0x0108	264 / 40265	RW	100% value for analog output 2	signed integer, -32000...+32000 (ppm / ‰)	1000	

* - The new value is applied after restart.

** - Broadcast slave ID 0 can be used to assign a new ID to device with unknown ID. When addressing by ID 0 the device shall be the only Modbus instrument in the network. The device will not respond to Master command when addressed by ID 0.

*** - This value is dynamic and not kept in EEPROM after restart